

## Industrial Wall Mounted Fan

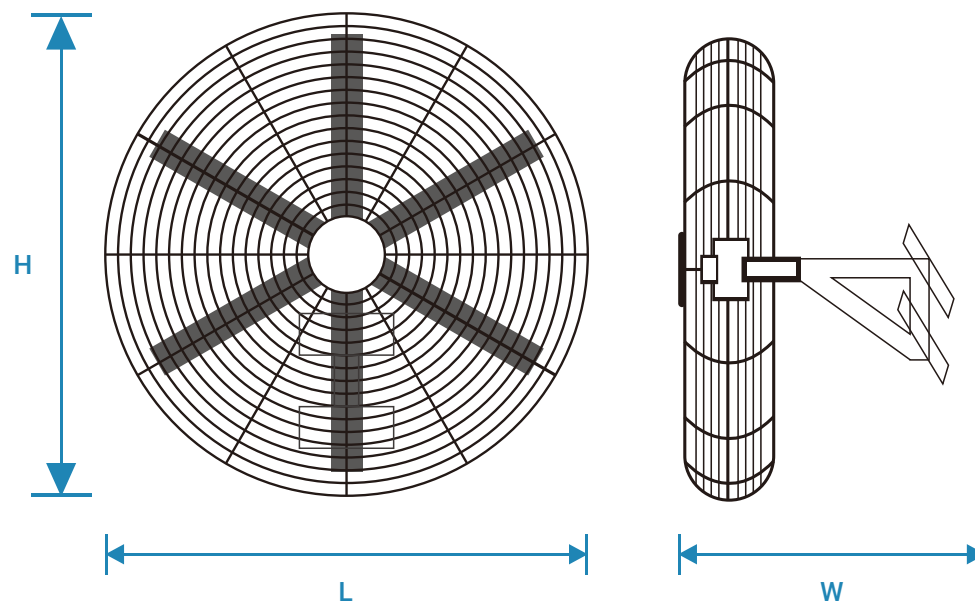
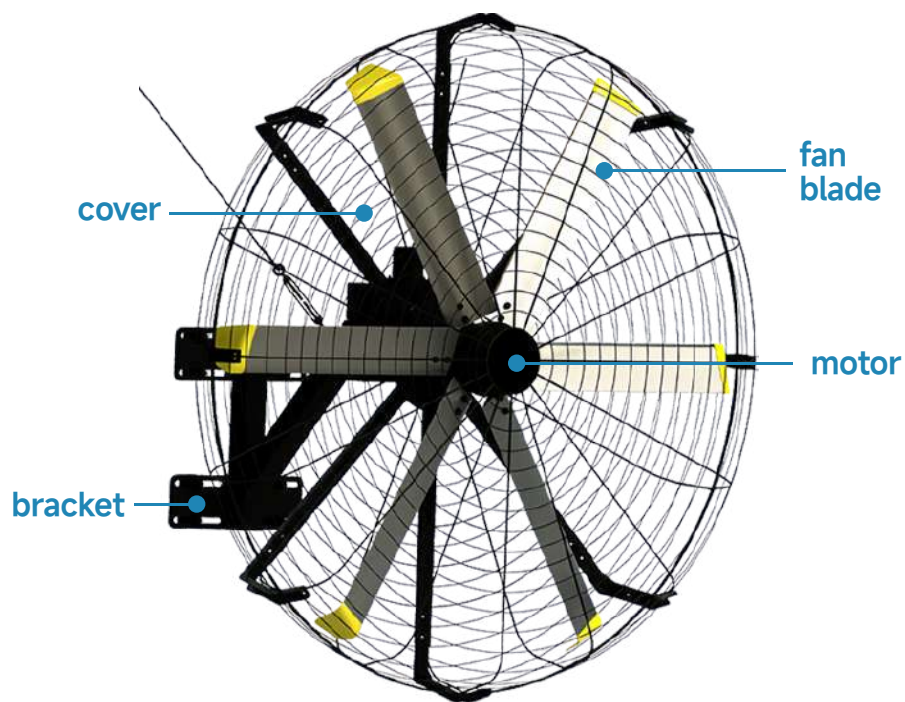

1. High Volume, Low Speed Airflow: Our HVLS fan moves large volumes of air at low speeds, ensuring effective and efficient ventilation for extensive areas.

2. Wall-Mounted Design: Save floor space with our sturdy wall-mounted fan, ideal for environments where floor space is at a premium.

3. Remote Control Convenience: Easily adjust fan settings with the included remote control, providing effortless operation and customization.

4. Durable Construction: Built with high-quality materials to withstand the demands of industrial use, ensuring long-lasting performance.

5. Quiet and Efficient: Experience powerful air movement with minimal noise, enhancing comfort without disrupting the work environment.

Diameter	Speed (RPM)	Specification	Weight (kg)	Power (KW)	Air Volume (m <sup>3</sup> /min)
2.0	180	07	100	0.55	1450
1.5	200	05	94	0.55	1200

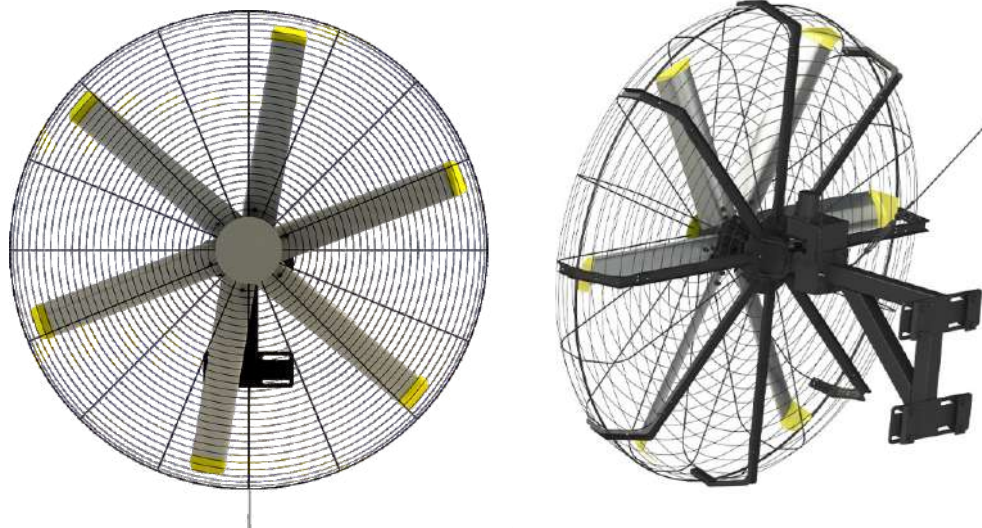

- Power:0.6KW;voltage:180V-260V;distance:35-40m;area:400 m<sup>2</sup>-500m<sup>2</sup>
- During operation, the motor temperature is 20°C, and the upper limit of motor temperature rise is 120°C.
- Two fans blow in close proximity, and their motor are not affected.
- The material of the fan blades are reinforced PP material.

- 1.Warehouses
- 2.Factories
- 3.Gymnasiums
- 4.Agricultural Facilities
- 5.Large Commercial Spaces

Enhance your industrial space with our HVLS industrial wall-mounted fan with remote control, offering superior air circulation, space-saving design, and convenient remote operation for a more comfortable and efficient environment.

